

Federal Republic of Nigeria

FY2018 Ex-Post Evaluation of Japanese Grant Aid Project

“The Project for Emergency Repair and Overhaul Works for the Jebba Hydro Power Station”

External Evaluator: Makoto Tanaka, ICONS Inc.

## 0. Summary

This Project was implemented at the Jebba Hydro Power Station, located beside the Niger River in Niger State, with the intent of securing a stable power supply from the power station, thereby contributing to the reduction of fuel for thermal power stations and of the consequent CO<sub>2</sub> emissions by carrying out the emergency repair and overhaul of No. 4 Generator. This generator had been producing much lower output because of a lightning-related accident which occurred in 2009. At the times of the commencement and the ex-post evaluation, the Project was consistent with Nigeria's *National Energy Policy*, aiming to increase power generation and development needs such as improvement of power facilities. Therefore, its relevance is high. Although the project cost was within the plan, the project period exceeded the plan. Therefore, its efficiency is fair. The indicators of expected quantitative and qualitative effects and quantitative impact effects of the Project have been achieved together with qualitative effects without negative impacts. Therefore, both its effectiveness and impact are high. No major problems were observed in the institutional/organisational and technical aspects and current status of the operation and maintenance system at the time of the ex-post evaluation. However, from the financial aspect, the payment rate of electricity bills is low, which may affect financial sources for future large-scale repair and overhaul of the power generation facilities. Therefore, its sustainability is fair.

In light of the above, the Project is evaluated to be satisfactory.

## 1. Project Description

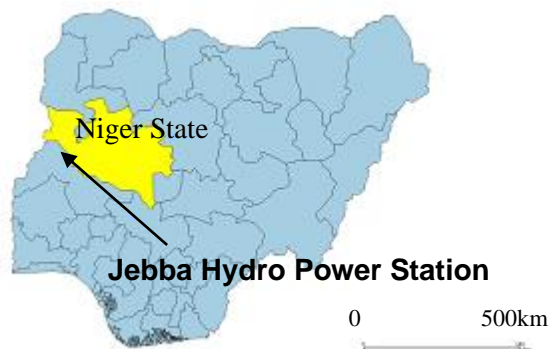

Project Location



Generator floor of the Jebba Hydro Power Station  
No. 1 Generator (front) – No. 6 Generator (back)

## 1.1 Background

In Nigeria, electric power supply was significantly insufficient because power demand was much higher than the available capacity of existing power supply facilities. Accordingly, the Government of Nigeria considered that ensuring electric power was one of the most important issues in its national development policies; it constructed new power stations and expanded and rehabilitated existing ones as well. It also promoted diversification of energy by developing not only generation by fossil fuels but also by renewable energy such as hydropower.

In such a power crunch, the Jebba Hydro Power Station, which has six generators with rated output<sup>1</sup> of 96.4 MW each, occupies an important place in Nigeria's power supply. However, the power station experienced damage to its No. 4 and No. 6 Generators as the result of an auxiliary power loss caused by a lightning strike in April 2009<sup>2</sup>. As a result, No. 6 was impossible to restart, and No. 4 could only operate at a maximum output of approximately one-half of the rated value. Still, the problems such as insufficient insulation of its coil and excessive vibration along its water turbine axis hindered their stable operation.

It was expected that improving the generating capacity of No. 4 Generator would contribute to the improvement of Nigeria's electricity by contributing to a continuous and stable power supply and by reducing its maintenance costs. It was also forecasted that this repair and overhaul would contribute to the diversification of energy sources and reduction of CO<sub>2</sub> emissions from fossil fuels by producing electric power from natural energy.

## 1.2 Project Outline

The Project was implemented at the Jebba Hydro Power Station, located beside the Niger River in Niger State to ensure a stable power supply from the power station, thereby contributing to the reduction of fuel requirements for the thermal power stations and the associated CO<sub>2</sub> emissions by carrying out the emergency repair and overhaul of No. 4 Generator, which was producing much lower output because of a lightning accident that occurred in 2009. The objective of the Project was to add a stable power supply to the Jebba Hydro Power Station, located beside the Niger River in Niger State, thereby reducing the fuel requirements for the thermal power stations and the corresponding CO<sub>2</sub> emissions by carrying out emergency repair and overhaul operations on No. 4 Generator, which was producing much lower output because of a lightning accident in 2009.

---

<sup>1</sup> A rated output of a generator is the designed output limit from continuous operation. The real output of a generator installed in a hydro power station varies from 0 to the rated output according to operation conditions such as water quantity, etc.

<sup>2</sup> Owing to loss of auxiliary power, it became impossible to compress air required to operate a circuit breaker (this circuit breaker has a tank that stores compressed air and should have been capable of operating the breaker several times even without power, but the tank had leakage then). Because of this, it was then impossible to turn the circuit breaker to "Off" and an accident occurred in which the current in the grid flowed inversely toward the generator, the coil of which was damaged by the extreme current (motoring).

Grant Limit / Actual Grant Amount	1,990 million yen / 1,990 million yen
Exchange of Notes Date /Grant Agreement Date	April 2011 / May 2011 (modified October 2011 <sup>3</sup> )
Executing Agencies	Responsible Ministry: Federal Ministry of Power (FMOP) <sup>4</sup> Implementing Agency: Jebba Hydro Electric Plc. (JHEP) <sup>5</sup>
Project Completion	January 2016
Target Area	Jebba, Niger State
Main Contractors	Marubeni Corporation Hitachi Mitsubishi Hydro Corporation (only for part of additional procurement)
Main Consultant	Yachiyo Engineering Co., Ltd.
Procurement Agency	Crown Agents Japan
Outline Design	January 2011 – February 2011
Related Projects	None

## 2. Outline of the Evaluation Study

### 2.1 External Evaluator

Makoto Tanaka, ICONS Inc.

### 2.2 Duration of Evaluation Study

This ex-post evaluation study was conducted with the following schedule.

Duration of the Study: October 2018 – December 2019

Duration of the Field Study: January 16, 2019 – February 6, 2019

### 2.3 Constraints during the Evaluation Study

The site survey was implemented only in the vicinity of the Jebba Hydro Power Station

<sup>3</sup> There were two (2) corrections, an extension of the grant deadline and a correction of typos. The former was a change of the deadline from 31 October 2011 as stated in the initial G/A to 30 April 2012, because the Banking Arrangements were expected to delay significantly owing to internal affairs by the Government of Nigeria, resulting in a late grant. The latter was a correction of an error (conflict of description of quantities) (Source of the above: documents provided by JICA).

<sup>4</sup> In 2016, after the completion of the Project, it merged with other ministries into the Federal Ministry of Power, Works, Housing (hereinafter referred to as the “FMPWH”).

<sup>5</sup> JHEP was an affiliated company of the Power Holding Company of Nigeria (PHCN). During the Project period, a nationwide reform of the electricity business was implemented, where the power generation business of the Jebba Hydro Power Station was transferred to a private company named Mainstream Energy Solutions Limited (hereinafter referred to as “MESL”) for the period of 30 years from November 2013. However, JHEP retains the property rights of the power station facilities, and MESL is fully responsible for their maintenance including large-scale repair and overhaul.

owing to limited time and costs, although it supplies power to an extensive area, including Niger State and the Federal Capital Territory. As the site is a zone with a sparse population, it is expected that the lifestyle and demand for electricity differ significantly from those of urban areas. Accordingly, the results of the qualitative survey implemented at the site cannot be understood as those representing the whole supply area but should only be considered as examples of the effects of the Project.

### **3. Results of the Evaluation (Overall Rating: B<sup>6</sup>)**

#### 3.1 Relevance (Rating: ③<sup>7</sup>)

##### 3.1.1 Consistency with the Development Plan of Nigeria

Increase of power generation was a main topic in Nigeria's development plans and energy policies such as the *7 Point Agenda* and *National Energy Policy* disclosed in 2007, before the commencement of the Project. The national development policy *Nigeria Vision 20:2020* and its action plan *The First National Implementation Plan for NV20:2020* (2010–2013), both established by the Government of Nigeria in 2010, considered the power sector as an important issue and promised to achieve greater efficiency in existing power stations. They also planned the direction for reducing the dependency of energy sources on petrol by diversifying them into hydro, natural gas, solar energy, etc. The Project aimed to improve electricity supply and to diversify electric power sources by recovering the capacity of the existing No. 4 Generator of the Jebba Hydro Power Station, which was operating at lower than rated output. It was judged that the Project should contribute to achieving targets in Nigeria's development plans and to supporting policies for the power sector.

As described in 3.4.1, there was a nationwide reform of the electricity business during the project period, where the generation business of the Jebba Hydro Power Station was conceded to MESL, a private enterprise, for 30 years from November 2013. In spite of this reform, the *7 Point Agenda* and *National Energy Policy* have remained valid at the time of the ex-post evaluation and power generation increase is still an important task to the nation. The national development policy *Nigeria Vision 20:2020* was revised in 2017 as *Nigeria Vision 30:30:30*. This revision transferred the main points of the policy from making existing power stations more efficient and diversifying energy sources (reducing dependency on petrol) to strengthening the national power generation capacity (especially hydro) and raising the production rate of renewable energy. These policies state that the increase of hydro power generation capacity will rely on constructing a new power station in Zungeru and repairing and overhauling the three existing hydro power stations of Jebba, Kainji and Shiroro. The Project contributes to this increase.

---

<sup>6</sup> A: Highly satisfactory, B: Satisfactory, C: Partially satisfactory, D: Unsatisfactory

<sup>7</sup> ③: High, ②: Fair, ①: Low

### 3.1.2 Consistency with the Development Needs of Nigeria

Before the commencement of the Project, Nigeria was suffering from chronic shortages of electric power. The generation capacity of the entire country decreased enormously owing to the damage to two of the six available generators at the Jebba Hydro Power Station caused by the 2009 accident. This unexpected decrease made the power shortage more acute. The Project was expected to enable the following:

- Improvement of power generating facilities, resulting in increasing maximum power generation.
- Reducing blackout times and stabilising supplied voltage and frequency, etc., thereby alleviating the problem of unavailable power at peak times.
- Alleviating problems involving blackouts, etc., during utilisation of medical equipment at hospitals, and electric tools at production sites.
- Expanding medical consultation time periods and scale, and improving productivity.
- The effects above contribute to improvement of daily life and economic development.

As the Jebba Hydro Power Station represented approximately 15% (just before the accident) or 10% (just after the accident) of Nigeria's total generation capacity, the Project was considered a suitable candidate for Japan's Grant Aid scheme, which in this case would contribute to alleviating the nation's power supply shortage at peak times and to expanding her power supply time through the emergency repair and overhaul of No. 4 Generator.

The supply and demand problems in Nigeria were still present at the time of the ex-post evaluation. The total actual generation capacity of Nigeria was approximately 5,000 MW at the end of 2018 (Source: the FMPWH), 9.6% (482 MWh) of which was generated at the Jebba Hydro Power Station. The total electric energy generated and sent to the grid<sup>8</sup> was 27,985 GWh<sup>9</sup> in 2016 and 31,024 GWh in 2017 (Source: the Nigerian Electricity Regulatory Commission, hereinafter referred to as the “NERC”), while that generated at the Jebba Hydro Power Station was 3,038.65 GWh in 2016 and 2,805.87 GWh in 2017 (Source: MESL). The electric energy generated by the Jebba Hydro Power Station accounted for 10.9% and 9.0% of the energy sent to the grid in 2016 and 2017, respectively<sup>10</sup>. Thus, since the Jebba Hydro Power Station plays an important role in the power supply in Nigeria, there is still a need for further repair and overhaul.

---

<sup>8</sup> The amount of energy sent to the grid is the total generated energy minus the energy consumed by the power stations.

<sup>9</sup> GWh (gigawatt-hour) is a unit of electric energy; 1 GWh is equal to 1 billion Wh (watt-hour).

<sup>10</sup> Because the generated energy from the Jebba Hydro Power Station includes the energy it consumes internally, the actual rate of energy sent to the grid is slightly less than the one described in the main text.

### 3.1.3 Consistency with Japan’s ODA Policy

Japan's development assistance with Nigeria attaches the greatest importance to setting up basic infrastructure, especially in the power sector. At the time of the planning (2011), it was confirmed that the Project was consistent with the *Programme for improving power supply* regarding the development issue “Power” in the priority area “Setting up basic infrastructure” of Japan's Country Assistance Policy for Nigeria. The Project also contributes to the target “to provide a stable power supply for the whole region”, one of the targets declared in the Fourth Tokyo International Conference on African Development (TICAD IV, 2008).

The Project has been highly relevant to Nigeria’s development plan and development needs, as well as Japan’s ODA policy. Therefore, its relevance is high.

## 3.2 Efficiency (Rating: ②)

### 3.2.1 Project Outputs

The planned and actual outputs of the Project are listed in Table 1.

Table 1. Planned and Actual Outputs of the Project

Planned (at the appraisal)	Actual (at the ex-post evaluation)
1) Procured equipment: (1) Stator core and associated parts (2) Stator coil and associated parts (3) Rotor pole (4) Rotor rim support modification parts (5) Current transformer for measuring instruments (6) Other parts and instruments 2) Consulting services: • Detailed Design (D/D) • Supervision of Procurement	1) Procured equipment: (1) Stator core and associated parts (2) Stator coil and associated parts (3) Rotor pole (4) Rotor rim support modification parts (5) Repair parts and instruments (including current transformer for measuring instruments) 2) Consulting services: • Detailed Design (D/D) • Supervision of Procurement

As shown in Table 1, the outputs were achieved as planned. In the table, (5) and (6) of the planned and (5) of the actual only differ in expression. The modification was made in order to clarify the fact that “Other parts” in the planned category includes repair parts (Source: interviews with the Japanese consultant).

### 3.2.2 Project Inputs

#### 3.2.2.1 Project Cost

In the original plan, the grant limit in the E/N was JPY 1,990 million and the costs disbursed by the Nigerian side were approximately JPY 106.8 million. The actual disbursement by the

Japanese side was JPY 1,987 million<sup>11</sup>, which was slightly lower than planned, and all the costs to be borne by the Nigerian side were implemented<sup>12</sup>.

### 3.2.2.2 Project Period

In the original plan, the project period was 1 year and 10 months (22 months) from March 2012 to December 2013<sup>13</sup>. The actual project period was 47 months from March 2012 to January 2016, longer than planned (214%). The timeline was as follows: the Detailed Design was carried out for 10 months from March 2012 to December 2012 (including the tender period from June 2012 to December 2012), the main work took place over 34 months from April 2013 to January 2016. According to documents provided by JICA, etc., such delay in the project period was caused mainly by the following three factors.

- (1) After concluding the G/A, the Banking Arrangements were delayed owing to internal affairs by the Government of Nigeria, resulting in a late grant (6 months late).
- (2) After the result of the tender of the equipment procurement on 2 December 2012, it was reported that the security at the site worsened<sup>14</sup>; the contract between the Procurement Agent and the main contractor was put off until the deadline of the tender, 2 April 2013 (3 months late).
- (3) The repair and overhaul of the generator required separating the generator axis from the water turbine axis. This work required supervision by supervisors (S/V) dispatched from Andritz AG, an Austrian company that manufactured the water turbine. However, their dispatch was delayed. An overhead traveling crane in the power station had also been out of order. The repair was entrusted to a Chinese company, which delayed as well. Poor security at the site<sup>15</sup> was at least partially responsible for both delays (21 months).

Of the above-mentioned three factors, (2) would have been a force majeure (poor security), as the level of prohibitions involving visits to Nigeria from Japan (practically forcing anyone in the country to evacuate) should be deduced from the project period in the evaluation methodology. The delays in (3) were also caused by poor security, but should not be totally attributed to poor

---

<sup>11</sup> This amount includes disbursement after project completion. Because the Project is a Procurement Agent project, the amount disbursed by JICA was JPY 1,990 million, which is equal to the grant limit.

<sup>12</sup> However, no reference was located to confirm the amount disbursed by the Nigerian side.

<sup>13</sup> According to the ex-ante evaluation paper, the project period is 23 months, but the report does not state what event was marked as the project commencement. The schedule in the Preparatory Survey Report states that the project period lasted 21.5 months, starting with the Detailed Design. The Evaluator adopts 22 months as the period, counting the partial months including the start and end of the period as one month each.

<sup>14</sup> After the Preparatory Survey, a state of emergency was declared in parts of Yobe, Borno, Plateau and Niger States and the border was closed on 31 December 2011. This declaration was lifted in July 2012, but there still occurred many kidnappings and murders by extremist groups as well as other conflicts among inhabitants afterward (Source: documents provided by JICA, etc.).

<sup>15</sup> A state of emergency had been declared in Borno, Yobe and Adamawa States on 14 May 2013, and was still not lifted at the time of the Ex-post Evaluation.

security because security was at a similar level compared to that of the period after the start of site works in June 2015<sup>16</sup>. From the above, the project period in terms of the evaluation was 44 months, significantly longer than planned (200%)<sup>17</sup>.

Although the project cost was within the plan, the project period exceeded the plan. Therefore, the efficiency of the Project is fair.

### 3.3 Effectiveness and Impacts<sup>18</sup> (Rating: ③)

#### 3.3.1 Effectiveness

##### 3.3.1.1 Quantitative Effects (Operation and Effect Indicators)

The generators at the Jebba Hydro Power Station followed the history shown in Figure 1: No. 1 – No. 6 Generators in ordinary operation → (lightning accident) → No. 6 suspended and No. 4 operated with limited output → (site works of the Project started) → only Nos. 1, 2, 3 and 5 operated → (site works completed) → No. 1 – No. 5 Generators in normal operation. Because the same conditions as before have not been realised after the Project (only five of six generators are in operation), it is impossible to compare the status before and after the Project. In addition, the auxiliary power<sup>19</sup> of the power station, which is necessary for operating the power station itself and its subsidiary facilities on the site, is supplied from the odd-numbered generators (Source: interviews with power station staff of MESL). This means that each generator bears a different electrical load. Accordingly, examination is required to determine quantitative indicators that represent the quantitative effects of the Project and its target and baseline values.

---

<sup>16</sup> The Embassy of Japan in Nigeria and JICA Nigeria Office surveyed security of the site in March 2013 and concluded that it was possible to agree on the contract between the Procurement Agent and the main contractor on 2 April 2013, the deadline of the tender. The contractor reported that the security measures at the Jebba Hydro Power Station were adequate (Source: documents provided by JICA).

<sup>17</sup> However, further delays did not occur after the site work began in June 2015.

<sup>18</sup> Sub-rating for Effectiveness is considered in combination with Impacts.

<sup>19</sup> Auxiliary power is supplied not only to the power station itself but also to residential zones, schools, hospitals and gatekeepers' offices etc. in an area of more than 10 km<sup>2</sup>, and to approximately 260 residences (Source: interviews with power station staff of MESL and site visits).



		April 2009 Lightning accident No. 4 & 6 damaged	June 2015 Repair & overhaul of No. 4 started	February 2016 Operation of No. 4 restarted
No. 1,3,5	Supplying to the grid and auxiliary			
No. 2	Supplying to the grid (except auxiliary)			
No. 4	Supplying to the grid (except aux.)	Supplying to the grid (except auxiliary) with limited output	(Repair works, operation suspended)	Supplying to the grid (except aux.)
No. 6	Supplying to the grid (except aux.)	Operation suspended		

Figure 1. Operation status of the generators at the Jebba Hydro Power Station

In the Preparatory Survey Report of the Project, (1) maximum output, (2) annually generated energy and (3) number of major accidents were assumed as quantitative indicators. In the ex-post evaluation, quantitative indicators and their target and baseline values are to be assumed in consideration of the following:

- The Evaluator adopts the functionality rate<sup>20</sup> as a complementary quantitative indicator, because maximum output is a value that is specific to each generator and is difficult to consider as a reliable indicator in this case.
- Because the functionality rates of the odd-numbered generators which supply auxiliary power tend to be larger than the even-numbered generators, the Evaluator adopts the average functionality rate<sup>21</sup> of the five generators (No. 6 is excluded) as Quantitative Indicator (1)', and the single functionality rate of No. 4 Generator as Quantitative Indicator (1)".
- Regarding the functionality rates, the actual values in 2010 are assumed as the baseline values and those in 2008 as the target values, to be compared with the actual values after project completion, in order to compare the scenario where only five generators are operating.
- In the original plan, an indicator of stable power supply was assumed to be that the energy annually generated from No. 4 Generator would be maintained at the level before the

<sup>20</sup> A functionality rate is a rate of operating time in a certain assumed period such as one year, etc. regardless of output.

<sup>21</sup> It appears that the functionality rate of No. 4 Generator, which was damaged in the accident, was intentionally lowered in 2010 to reduce its electrical load. It is also expected that the other four generators were operated at higher functionality rates. Because of this, the Evaluator assumes the average of the five generators including No. 4 as the target value. In fact, the functionality rate of each generator in 2010 was 94.2% for No. 1, 71.1% for No. 2, 87.0% for No. 3, 48.3% for No. 4, and 71.6% for No. 5, and the average of the five generators was 74.5%. The functionality rate of No. 4 is lower than the average of the five, and that of No. 2, which does not supply auxiliary power.

accident, and the average of the annually generated energy from 1999 to 2008 would apply. However, the generators other than No. 6, including No. 4, relatively increased output in 2010 after the accident and before the Project because of the stoppage of No. 6. While No. 6 was operating from 1999 to 2008, the energy generated by No. 4 was relatively low. Because of this, the average of the annually generated energy in this period was less than the actual value in 2010, and is thought to be too low as the target value. From the above, the baseline value of the annually generated energy is assumed to be the actual value in 2010 in the same way as the functionalities are considered, and the target considered was to maintain the output level achieved in 2010. The average of the actual values from 1999 to 2008 is adopted only as a reference value. Each of the target, baseline and reference values was to be compared with the actual values after the completion<sup>22</sup>.

- The definition of a major accident is an accident entailing stoppage of 1 month or longer. It was targeted that no such accidents would take place after the completion.
- In the original plan, the actual values that should be compared with the target values were assumed as the values 3 years after completion. However, the actual values in 2018 are compared with the target values, because no values were available for 2019, which would represent the actual 3 years after completion.

Summarizing the discussion above, the achievements of the quantitative indicators are shown in Table 2.

---

<sup>22</sup> Because the output of hydroelectric power generation is affected by water quantity and electric load (demand), etc., it is better to adopt the value adjusted with the water quantity of the Niger River as the indicator of annually generated energy (Source: documents provided by JICA). However, the Evaluator adopts values without adjustment for both baseline and compared values because adjusted values after 2011 were not available.

Table 2. Achievements of the quantitative indicators

	Baseline	Target	Actual		
	2010	2018	2016	2017	2018
(1) Maximum output [MW]	45.9 <sup>*1</sup>	96.4	96.4	96.4	96.4
(1)' Average functionality rate of No. 1 – No. 5 Generators [%]	74.5	74.5 (66.3) <sup>*2</sup>	79.8 <sup>*3</sup>	74.8 <sup>*4</sup>	73.4 <sup>*5</sup>
(1)" Single functionality rate of No. 4 Generator [%]	48.3	58.6 <sup>*6</sup>	64.0 <sup>*7</sup>	64.5 <sup>*8</sup>	62.6
(2) Annually generated energy [GWh] <sup>*9</sup>	336	336 (267) <sup>*10</sup>	482 <sup>*11</sup>	475	445
(3) Number of major accidents (entailing stoppage of 1 month or longer)	1	0	0	0	0

\*1: Because No. 4 Generator operated with output that was less than half of its rated output, 96.4 MW, in consideration of damage by the accident, the actual maximum output in 2010 is adopted as the baseline.

\*2: The actual value in 2008, before the accident, is provided here as a reference.

\*3: No. 4 Generator started operating on 10 February 2016.

\*4: No. 4 Generator stopped operating for 40 days for the purpose of large-scale regular maintenance.

\*5: No. 3 Generator stopped operating for 5 months in total for the purpose of large-scale maintenance.

\*6: Actual value in 2008.

\*7: No. 4 Generator started operating on 10 February 2016.

\*8: No. 4 Generator stopped operating for 40 days for the purpose of large-scale regular maintenance.

\*9: Values without adjustment.

\*10: Annual average of 1999 – 2008 is provided here for reference.

\*11: Actual value in the 11 months from February to December 2016.

Source: documents provided by JICA and prepared by MESL.

#### Quantitative indicator (1): Maximum output

The Jebba Hydro Power Station is equipped with six generators of 96.4 MW rated output each, referred to as No. 1 – No. 6 Generators. No. 4 and No. 6 Generators were damaged by an accident in April 2009. As a result, No. 6 Generator stopped operating and No. 4 Generator operated with an output less than its maximum rated output in consideration of the damage it sustained. The actual maximum output of No. 4 Generator was 45.9 MW in 2010, after the accident and before the Project. The plan of the Project assumed the target value of maximum output as 100% of the rated output of 96.4 MW after project completion (2018). As a result of the Project, the maximum output of No. 4 Generator achieved 96.4 MW, the same as that before the accident, which was achieved in the water-rich season from June to September (Source: interviews with power station staff of MESL).

#### Quantitative indicator (1)': Average functionality rate of No. 1 – No. 5 Generators

#### Quantitative indicator (1)": Single functionality rate of No. 4 Generator

From Table 2, the average functionality rate of the five generators in 2016 and 2017 and the

single functionality rate of No. 4 Generator after 2016 exceeded the target (baseline) and reference values each. The average functionality rate of the five generators in 2018 is below the target (baseline) value, although it exceeds the reference value; this is because there was a long-term (5-month) stoppage due to a large-scale repair of No. 3 Generator.

From the above results, the Evaluator judges that the indicator of functionality rates has been achieved.

#### Quantitative indicator (2): Annually generated energy

From Table 2, the generated energy in each year after the completion significantly exceeds the target (baseline) value. The total energy generated by No. 4 Generator in the 1,056 days following completion, from 10 February 2010 to 31 December 2018 (the sum of the actual values of annually generated energy in the three years in Table 2)<sup>23</sup> is 1,402 GWh, which is equivalent to 485 GWh per year (365 days). This is 1.4 times the target (baseline) value of 336 GWh and 1.8 times the reference value of 267 GWh. From these results, the Evaluator judges that the indicator of annually generated energy has been achieved.

#### Quantitative indicator (3): Number of major accidents

No major accidents entailing stoppage of 1 month or longer took place on No. 4 Generator in the 1,056 days following completion, from 10 February 2016 to 31 December 2018. During this period, its operation was suspended 10 times due to accidents and disorders, for 428 hours and 32 minutes (approximately 18 days) in total (Source: documents prepared by power station staff of MESL). From the above data, the Evaluator judges that the indicator of number of major accidents has been achieved.

#### 3.3.1.2 Qualitative Effects (Other Effects)

As a qualitative effect of the Project, reduction in the repair and maintenance costs of the power station was expected. The Evaluator examined the repair and maintenance costs after 2014, the year just before the repair and overhaul of No. 4 Generator in the Project, when the generation business of the Jebba Hydro Power Station was conceded to MESL, a private enterprise, from JHEP, a public one, in November 2013, as described above. Since 2016, after the completion of the Project, the repair and maintenance costs of the Jebba Hydro Power Station have been decreasing because of the increased efficiency introduced by the private company (Source: interviews with the managing director/CEO of MESL). Although no data was obtained on the maintenance costs specific to the Jebba Hydro Power Station, the total costs of the Jebba and Kainji<sup>24</sup> Hydro Power Stations, both of which are operated by MESL, were

---

<sup>23</sup> This includes six planned stoppages for maintenance of 2,615 hours and 25 minutes (109 days) in total.

<sup>24</sup> The total generating capacity of the Kainji Hydro Power Station is 760 MW, 440 MW of which is in operation.

obtained, and are listed in Table 3.

Table 3: Repair and maintenance costs of the Jebba and Kainji Hydro Power Stations

	2014	2015	2016	2017
Repair and maintenance costs [ $\times 1,000$ NGN <sup>25</sup> ]	1,166,225	805,434	410,896	1,548,106

Source: MESL's financial statements

The total repair and maintenance costs of the Jebba and Kainji Hydro Power Stations in 2016, the year of the completion, declined from those in 2014, the year just before the start of the site works, by 65%. A large amount of costs were posted in 2017 because of large-scale repair and overhaul projects involving three generators at the Kainji Hydro Power Station (Source: interviews with power station staff of MESL, etc.).

From the above data, the Evaluator judges that the effect of reduction of repair and maintenance costs has been achieved.

### 3.3.2 Impacts

#### 3.3.2.1 Intended Impacts

Before the Project, quantitative and qualitative effects were expected: as a quantitative effect, reduction of greenhouse gases, and as a qualitative ones, “development of local industries”, “stable operation of medical facilities” and “improvement of living environment of local residents”.

#### (1) Quantitative effects<sup>26</sup>

If the target (baseline) value of 336 GWh and the reference value of 267 GWh of annually generated energy shown in 3.3.1.1 are considered as the electric energy used to measure the reduction of greenhouse gases, the target (baseline) and reference reduction values are 283,000 and 225,000 t-CO<sub>2</sub>/year respectively. The annually generated energy per year after the completion of 485 GWh contributes a reduction of 409,000 t-CO<sub>2</sub>/year. The latter is 1.4 times the target (baseline) value and 1.8 times the reference value. From the above results, the Evaluator judges that the expected quantitative effect has been achieved.

#### (2) Qualitative effects

A qualitative survey was carried out in the ex-post evaluation in order to evaluate the

<sup>25</sup> NGN stands for Nigerian naira, the Nigerian currency: NGN 1,000 was equivalent to approximately JPY 302 (Japanese Yen) as of the end of 2018.

<sup>26</sup> This calculation of greenhouse gas emission reduction follows the *Approved Consolidated Methodology for Grid-connected Electricity Generation from Renewable Sources* (ACM0002) recommended by the United Nations Framework Convention on Climate Change (UNFCCC), in the same manner as was applied in the Preparatory Survey.

qualitative effects achieved by stabilised power supply. Its outline is described in Table 4.

Table 4: Outline of the qualitative survey

Items	Contents
Purpose	To confirm “development of local industries”, “stable operation of medical facilities” and “improvement of living environment of local residents” due to the stabilisation of electricity supply
Target area	The areas around the Jebba Hydro Power Station <sup>27</sup>
Target customers	<ul style="list-style-type: none"> <li>• 20 individual customers (residents) around the Jebba Hydro Power Station               <ul style="list-style-type: none"> <li>• 10 residents from the left bank of the Niger River (Niger State)</li> <li>• 10 residents from the right bank of the Niger River (Kwara State)</li> </ul> </li> <li>• 6 institutional customers around the Jebba Hydro Power Station               <ul style="list-style-type: none"> <li>• 2 schools (both are public primary schools<sup>28</sup> in Niger State)</li> <li>• 2 hospitals (1 secondary referral hospital<sup>29</sup> established by Kwara State, 1 private hospital)</li> <li>• 2 factories (1 large-scale paper mill, 1 small-scale sawmill)</li> </ul> </li> </ul>
Method	<ul style="list-style-type: none"> <li>• For institutional customers, at least two persons in charge were interviewed in order to judge the Project effects not on individuals but on target institutions. Concrete improvement cases extracted from their responses are used to make an evidence-based evaluation.</li> <li>• For local residents, they were asked whether their occupations require commutation and whether they are agriculture, stock farming, or others, and then free-form responses to the Project effects were asked.</li> </ul>

The results of the qualitative survey are summarised in Table 5.

<sup>27</sup> The areas around the Jebba Hydro Power Station are targeted because they fall in the area where electricity is supplied from the Jebba Hydro Power Station and the residents are likely to experience the effects of stabilisation of electricity supply directly.

<sup>28</sup> Both are primary schools that implement the Universal Primary Education (UPE) prescribed by the Government of Nigeria, equipped with audio-visual teaching aids for English education and personal computers for programming education.

<sup>29</sup> A secondary referral hospital is a medical facility that accepts patients transferred from other medical facilities first examined the patients.

Table 5. Summary of the results of the qualitative survey

Expected impacts	Materialisation
Development of local industries	Since 2016, electricity supply has been greatly improved: the period of power failures has drastically decreased, and variances in voltage and frequency have been reduced. One factory was examining whether to expand its business because of these improvements.
Stable operation of medical facilities	Since 2016, the quality of medical service has improved and the reputation of medical facilities has increased: malfunction of medical equipment has decreased, and medical consultations have become more rapid owing to the reduction of idle times caused by power failures. One medical facility expanded its consultation time period as a result.
Improvement of living environment of local residents	Since 2016, the quality of primary education and the reputation of primary schools have improved. The improvement has enabled audio-visual and computer education through the procurement of equipment for such education because of the stable electricity supply necessary to safely use such equipment. According to the improvement of electricity supply from 2016, the living environment of local residents has been improved.
Others	Waste including asbestos was expected to be generated in the Project (see 3.3.2.2 (3)). However, there was no interviewee who pointed out any problems regarding asbestos.

From the above survey responses, the Evaluator believes that all the expected qualitative effects were accomplished.

### 3.3.2.2 Other Positive and Negative Impacts

The Evaluator examined (1) Impacts on the natural environment, (2) resettlement and land acquisition and (3) Other impacts, in addition to the quantitative and qualitative effects described in 3.3.2.1.

#### (1) Impacts on the natural environment

According to *JICA guidelines for environmental and social considerations* (established in April 2010), it was judged that adverse impacts by the Project on the environment were not serious, taking into account the characteristics of the sector, the Project, and the site; the Project was classified as a Category B project.

In addition, Nigerian domestic laws do not require a report of environmental impact assessment (EIA) regarding the Project.

In interviews with local residents for the qualitative survey in the ex-post evaluation, there were no interviewees who pointed out any negative impacts on the natural environment caused by the Project (Source: results of the qualitative survey).

Furthermore, the ex-ante evaluation designated that waste containing asbestos would be

produced during refurbishing of the insulated coil, which would be removed and disposed of under regulated procedures. The ex-post evaluation clarified the following on this point:

- Asbestos that was contained in the machinery to be repaired and overhauled was treated according to Nigerian domestic regulations. The safety of the workers in charge and the treatment of the waste were appropriate, and accordingly, no environmental problems occurred (Source: interviews with the managing director/CEO and power station staff of MESL).
- A report on the work concerned with asbestos was submitted to JICA Nigeria Office. The report states that the work was carried out under regulated procedures and no health hazard situations occurred (Source: interviews with the Japanese consultant).
- There were no reports pointing out environmental pollution with asbestos (Source: interviews with surrounding residents).

From the above observations, the Evaluator judges that asbestos was appropriately handled without causing any negative influence on the surrounding residents.

## (2) Land acquisition and resettlement

According to the ex-ante evaluation, the Project was planned to be implemented solely within the site of the existing power station without land acquisition and resettlement. At the time of the ex-post evaluation, the Project has not caused land acquisition and resettlement (Source: interviews with MESL and surrounding residents).

## (3) Other impacts

The Evaluator recognises no positive or negative impacts on gender, as no problems related to gender are reported in documents related to the Project, and no indications regarding gender were mentioned in the qualitative survey.

As described above, the Project has achieved its objectives. Therefore, the effectiveness and impacts of the Project are high.

## 3.4 Sustainability (Rating: ②)

### 3.4.1 Institutional / Organisational Aspect of Operation and Maintenance

According to the *Electric Power Sector Reform Act*, which was officially put into force in March 2005, before the planning of the Project, the National Electronic Power Authority, which had been in charge of the Nigerian electricity business, was reformed and divided into the following companies: six generating companies (hereinafter referred to as “GenCo(s)”), one



transmission company, and eleven electricity distribution companies (hereinafter referred to as “DisCo(s)”). All these companies were established with 100% capitalisation by the Government. At the time of the planning, the implementing organisation of the Project was JHEP, one of the six GenCos, and the responsible ministry was FMOP. There was a nationwide reform of the electricity business during the project period, where the generation and electricity distribution businesses were conceded to private enterprises for limited periods. The generation at the Jebba Hydro Power Station, which was the focus of the Project, was conceded to MESL for 30 years from November 2013, as well as that at the Kainji Hydro Power Station, which is located 100 km upstream on the Niger River. Furthermore, the Nigerian electricity market was restructured in February 2015: the power generated by GenCos is sold to DisCos via Nigeria Bulk Electricity Trading (hereinafter referred to as “NBET”), as shown in Figure 2, then sold to customers<sup>30</sup>. In this timeframe, the FMOP was merged with other ministries and became the FMPWH in 2016, after the completion of the Project.

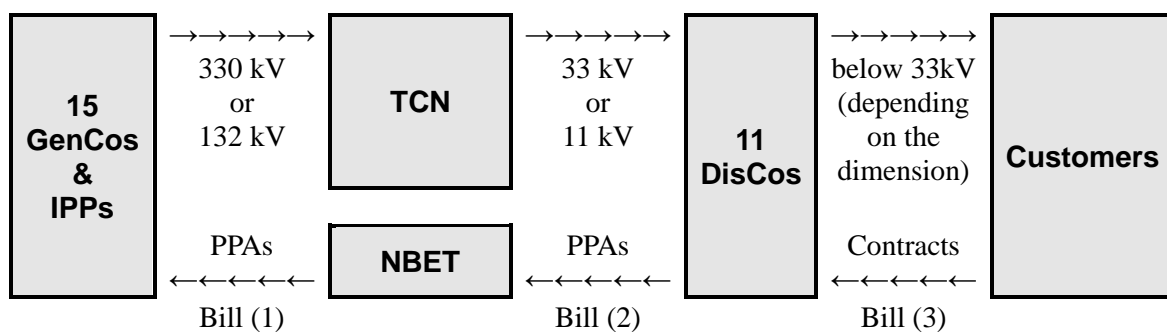

**[Legend]**

→→→→: electricity supply, ←←←←: electricity bills

**GenCos**: generating companies (including MESL), **IPPs**: independent power producers, **TCN**: The Transmission Company of Nigeria, **DisCos**: electricity distribution companies, **NBET**: Nigeria Bulk Electricity Trading, **PPAs**: Power Purchase Agreements

\* This figure excludes direct trades between NBET and specified customers.

\* Surplus power is sent directly from GenCos to DisCos.

Source: Prepared by the Evaluator, referring to documents provided by NBET and interview results

Figure 2. Nigerian electricity market

This electricity market is conducted under the supervision of three entities: NBET, the NERC and the Department of Market Operations of the TCN. The TCN measures energy sent to the grid, peak power, voltage, frequency, and transmission losses every day and reports them to the NERC, who records them.

MESL, as one of the players in this electricity market, operates and maintains the Jebba and Kainji Hydro Power Stations. The numbers of MESL staff members allocated to the two power

<sup>30</sup> Fifteen (15) private companies have entered the power generation business successively, including ones just under preparation, as of October 2018. Electricity transmission is still implemented by the Transmission Company of Nigeria (hereinafter referred to as the “TCN”), a 100% government-owned company, as it is difficult to fit private businesses into this sector. Separately, electric power as a physical entity is sent from generating companies to electricity distribution companies via transmission facilities owned and managed by the TCN.

stations are as follows:

- Technical staff members at the Jebba Hydro Power Station: 82;
- Non-technical staff members at the Jebba Hydro Power Station: 8;
- Technical staff members at the Kainji Hydro Power Station: 89;
- Non-technical staff members at the Kainji Hydro Power Station: 14.

MESL's technical divisions are categorised into operations and maintenance departments. The managers of both departments oversee both the Jebba and Kainji Hydro Power Stations. The staff members belong to one of the two power stations, but sometimes make trips to the other if necessary. Part of the indirect divisions<sup>31</sup>, which had been operated directly by the company, were outsourced in 2017 along with the layoff of workers who had been in charge of them (Source: interviews with power station staff of MESL, etc.). Although the number of employees was decreased compared to the time of JHEP, the amount of work has also been reduced owing to rationalisation and outsourcing, and a sufficient number of personnel necessary to operate the power stations is maintained. Most of the employees who started working in operations before the concession were retained, while some new employees have been engaged by MESL. Regarding their command chain, headquarters executives and the manager who oversees operations and maintenance on site have managed both the Jebba and Kainji Hydro Power Stations at the same time since the concession in November 2013. If, for example, a problem occurs at one of the two power stations, engineers at the other station can be involved in tackling the problem through telephone calls (Source: interviews with directors and power station staff of MESL).

From the above findings, the institutional / organisational aspects of operation and maintenance are thought to be sufficient.

#### 3.4.2 Technical Aspects of Operation and Maintenance

Since its start-up in 1985, the Jebba Hydro Power Station had been operated and maintained by the power station staff of JHEP. Most of the employees continue operating the power station under MESL, keeping their original positions, after the business was conceded in November 2013. Because the repair and overhaul of the generator in the Project mainly consisted of replacing existing equipment, machinery and parts, current personnel are fully capable of utilizing the generator based on conventional operation and maintenance methods. MESL issued a manual called the Law Book that describes technical topics such as operation, inspection, maintenance and responses to abnormal situations. The company also makes an effort to upgrade internal technical skills by having their technical staff participate in training sessions

---

<sup>31</sup> Training facilities, hospitals, farms, security personnel, canteens and vehicle driving have been outsourced.

conducted at governmental training centres, etc. Newly hired technical staff participates in long-term training for graduate engineers before being attached to power stations (Source: interviews with the managing director/CEO and power station staff of MESL).

From the above findings, the Evaluator judges that the technical aspects of operation and maintenance are sufficient.

### 3.4.3 Financial Aspects of Operation and Maintenance

At the time of the ex-post evaluation, MESL established a plan of maintenance for all generators at the Jebba and Kainji Hydro Power Stations, including No. 4 of the former, and a build-up of the number of generators at the two power stations, including costs and total budget (Source: MESL company profile and interviews with the managing director/CEO of MESL). Although MESL does not post allowances for potential income decreases such as the one that occurred in 2009 or for repair and overhaul (Source: interviews with the managing director/CEO of MESL), it accumulates retained earnings to cover the costs for repair and maintenance expected under normal operations. In fact, MESL has disbursed the amount listed in Table 3, compared to its financial status shown in Table 9 below.

However, there are some doubts regarding ensuring the budget.

As described above, the electricity trading via NBET started in February 2015. Table 6 shows the billing amounts, payments and payment rates for electricity sold by MESL to NBET in the 27 months from August 2016 to October 2018. Table 7 shows the total billing amounts, payments and payment rates for electricity sold by all GenCos that contracted Power Purchase Agreements (PPAs) in the same 27 months. Table 8 shows data about the electricity sold by NBET to all 11 DisCos in the same period<sup>32</sup>.

Table 6. Billing amounts, payments and payment rates for electricity sold by MESL to NBET in the 27 months from August 2016 to October 2018

	Aug. – Dec. 2016	Jan. – Dec. 2017	Jan. – Oct. 2018
Billing amount [ $\times 1,000$ NGN]	14,642,267	30,224,943	21,951,073
Payment [ $\times 1,000$ NGN]	3,515,715	8,095,891	5,830,646
Payment rate [%]	24.01	26.79	26.56

Source: NBET

<sup>32</sup> NBET adopts a policy to synchronise the rate of payment by electricity distribution companies (those in (2) in Figure 2 and Table 7) and the payment rate to generating companies (those in (1) in Figure 2 and Table 8) (Source: interviews with NBET).

Table 7. Total billing amounts, payments and payment rates for electricity sold by all GenCos to NBET in the 27 months from August 2016 to October 2018

	Aug. – Dec. 2016	Jan. – Dec. 2017	Jan. – Oct. 2018
Total billing amount [×1,000 NGN]	179,384,172	527,396,381	499,829,322
Total payment [×1,000 NGN]	43,037,516	137,332,617	135,707,547
Payment rate [%]	23.99	26.04	27.15

Source: NBET

Table 8. Total billing amounts, payments and payment rates for electricity sold by NBET to all 11 DisCos in the 27 months from August 2016 to October 2018

	Aug. – Dec. 2016	Jan. – Dec. 2017	Jan. – Oct. 2018
Total billing amount [×1,000 NGN]	179,342,268	493,017,967	456,804,409
Total payment [×1,000 NGN]	43,037,516	130,235,145	101,463,924
Payment rate [%]	24.00	26.42	22.21

Source: NBET

After electricity trading via NBET started in February 2015, MESL sells the electricity it generates to NBET and claims payment, but as is evident from the tables, only part of the billing is paid. This is because the payment rate is kept equal to the rate of payment for electricity sold by NBET to DisCos, which is only 20% – 30%, as shown in Table 8 (Source: interviews with NBET). Although MESL has established a plan of maintenance for all generators at the Jebba and Kainji Hydro Power Stations, and in addition, plans a build-up of generators, it cannot provide large-scale repair and overhaul and build-up of generators in the foreseeable future. However, these plans will become feasible if the guarantee system supported by government funds described below is implemented.

The Government of Nigeria recognises such problems of non-payment of electricity bills and continues to make an effort to raise the payment rate, while it in a phased manner raises bills to more closely reflect the cost of electricity. In 2019, the FMPWH decided to guarantee the payments from NBET to DisCos to the extent of 80% for hydro and 90% for thermal power generation, and established a fund for the guarantee. The FMPWH is also to implement a policy in 2019 to invite meter asset providers (MAP) and entrust them with the tasks of installing meters at customer locations and producing electricity bills based on meter records to promote payments from customers to DisCos ((3) in Figure 2) as financial sources for the electricity sector function (including maintenance of generating facilities). It expects revenues from petrol exports and carbon credits to provide the financial sources needed to implement the policy (Source: interviews with the FMPWH). However, attention must be paid to the probability that such payment guarantee by a governmental fund might ultimately place a national burden on the

population in the form of taxes and might affect the self-help efforts of the entities concerned.

The financial status of MESL itself also relates to the sustainability of the Project. MESL's financial status in each year from 2014 to 2017 is shown in Table 9 (Source: MESL's financial statements)<sup>33</sup>.

Table 9. MESL's financial status

	2014	2015	2016	2017
Revenue	19,820,073	23,398,295	53,647,360	60,090,140
Total comprehensive profit/(loss) for the year	(4,004,126)	(4,905,109)	53,647,360 (345,874)	60,090,140 32,237,734
Total assets	88,874,275	100,134,966	152,397,648	186,829,864
(Included) Trade and other receivables (non-current)	378,570	532,567	1,317,807	660,951
(Included) Trade and other receivables (current)	12,410,070	20,118,789	1,317,807 57,576,732	660,951 86,734,424
(Included) Cash and cash equivalents	2,234,016	4,337,466	4,767,371	12,772,685
Total equity	(4,940,825)	6,736,201	4,767,371 6,390,327	11,743,273 32,399,807
			6,393,660	32,389,793

(The upper and lower numbers after 2016 represent the amount consolidated with a subsidiary and MESL's generated amounts, respectively. Unit: ×1,000 NGN. The numbers in parentheses represent negative values.)

According to the table, MESL's financial status has shown an improving trend since the concession in November 2013, and MESL posted a surplus in 2017. However, this tendency greatly depends on the fluctuation of finance costs (interest payments, etc.), and MESL does not accumulate the sufficient cash and cash equivalents necessary for future large-scale repair and overhaul of its generation facilities, because a part of the electricity sold to NBET is not paid for. As described previously, MESL is able to cover the costs for repair and maintenance expected under ordinary operations, but it does not post allowances for potential income decreases due to sudden stoppages, such as the one in 2009 or for other unplanned large-scale repair and overhaul operations: MESL might not be able to respond rapidly in terms of finance. Whether cash accumulation will be sufficient or not in the future cannot be predicted, as it depends on whether electricity bills will be consistently collected or not under the above-mentioned guarantee system.

On the other hand, the generators in operation at the Jebba Hydro Power Station, except No. 4, are operating beyond their rated lifetimes and could break down at any time. In fact, the power station output temporarily declined<sup>34</sup> in January 2019, during the site survey.

<sup>33</sup> MESL purchased a certain small company and made it a consolidated subsidiary on 26 April 2016. Its financial statements disclosed every year also describe the financial status of the previous year, sometimes with slight corrections (e.g. exchanges between operating and non-operating incomes). Table 9 is based on the latest corrections. The original financial statements have been audited by PricewaterhouseCoopers (PwC), which is headquartered in the United Kingdom.

<sup>34</sup> No. 5 Generator experienced disorders and stopped operating. Apart from this, part of the control system of the power station malfunctioned and accordingly part of the supply of the auxiliary power stopped temporarily. One of the reasons for the latter might be that no redundancy had been incorporated into the control system.

From the above evaluations, the Evaluator judges that the financial sustainability is fair.

#### 3.4.4 Status of Operation and Maintenance

Based on a defect inspection of the Project in January 2017, the status of the procured equipment listed in Table 1 was judged to be very good. According to MESL power station staff, the total energy generated by No. 4 Generator in the 1,056 days after completion, from 10 February 2010 to 31 December 2018, was 1,402 GWh, which is equivalent to 485 GWh per year (365 days). This is 1.4 times the baseline value of 336 GWh.

The Evaluator visited the Jebba Hydro Power Station and confirmed that the time and frequency of meter readings of every kind is conducted daily, that power station staff members are carrying these out, and that MESL has issued the Law Book, which describes technical topics such as operation, inspection, maintenance and responses to abnormal situations. During the site survey, the Evaluator witnessed an abnormal status (called a “system collapse”) that occurred occasionally, and confirmed that power station staff took appropriate actions to recover from the problem based on regulated procedures.

According to interviews with MESL power station staff members, MESL is voluntarily planning to repair and overhaul No. 6 Generator, which has been inoperative since the accident at the time of the ex-post evaluation. This will be under the responsibility of engineering, procurement and construction, and its main work will start within several years of the time of the ex-post evaluation. In addition, MESL does not operate No. 4 Generator under heavy loads.

From the above, the Evaluator judges that the status of operation and maintenance is good.

Some minor problems have been observed in the operation and maintenance from the financial perspective. Therefore, the sustainability of the Project effects is fair.

## **4. Conclusion, Recommendations and Lessons Learned**

### 4.1 Conclusion

This Project was implemented at the Jebba Hydro Power Station, located beside the Niger River in Niger State, with the intent of securing a stable power supply from the power station, thereby contributing to the reduction of fuel for thermal power stations and of the consequent CO<sub>2</sub> emissions by carrying out the emergency repair and overhaul of No. 4 Generator. This generator had been producing much lower output because of a lightning-related accident which occurred in 2009. At the times of the commencement and the ex-post evaluation, the Project was consistent with Nigeria's *National Energy Policy*, aiming to increase power generation and development needs such as improvement of power facilities. Therefore, its relevance is high. Although the project cost was within the plan, the project period exceeded the plan. Therefore, its efficiency is fair. The indicators of expected quantitative and qualitative effects and

quantitative impact effects of the Project have been achieved together with qualitative effects without negative impacts. Therefore, both its effectiveness and impact are high. No major problems were observed in the institutional/organisational and technical aspects and current status of the operation and maintenance system at the time of the ex-post evaluation. However, from the financial aspect, the payment rate of electricity bills is low, which may affect financial sources for future large-scale repair and overhaul of the power generation facilities. Therefore, its sustainability is fair.

In light of the above, the Project is evaluated to be satisfactory.

## 4.2 Recommendations

### 4.2.1 Recommendations to the Executing Agencies

(1) To MESL: Ensure redundancy in the generating facilities' electrical circuits.

All the generators at the Jebba Hydro Power Station other than No. 4 are operating beyond their designed lifetimes and might well break down at any time. If any of them stops operation, the generator should be disconnected from the grid to avoid damage caused by any abnormal current flowing through the affected generator or other generators. It is recommended that redundant electrical circuits related to the auxiliary power are implemented so that auxiliary power is available even in such cases.

(2) To the FMPWH: Monitor the electricity market

The electricity market, which is under the direction of the FMPWH, operates on the basis of two-way chains: the flow of electricity: GenCos → TCN → DisCos → customers, and money: customers → DisCos → NBET → GenCos. The Evaluator believes that it is first necessary to raise the payment rate from customers to DisCos. Once electricity is supplied at sufficient quantity and quality and the consumed energy is correctly metered, their willingness to pay will be improved. Consequently, it will raise the payment rate and eventually allow GenCos and DisCos to invest in improving power facilities. If electricity is not monitored and metered, their willingness to pay will not be improved, the above-mentioned flow of money will encounter significant bottlenecks, and cash and cash equivalents necessary for the maintenance of generators and other equipment will not be available. Solving this problem by a payment guarantee through government funds may be reasonable in the short term, but may lead to an ebb of customers' willingness to pay, moral hazard that providers hesitate to claim electricity bills from their payable customers, and burdens on the nation's population in the form of additional taxes needed to provide the payment guarantee. Hence, it is recommended that the FMPWH, as the supervising ministry, monitor the electricity market and support efforts to install meters at customer sites to facilitate good circulation of capital among the concerned parties: increase in payment rate by customers → improvement of financial status of DisCos →

increase in investments of facilities by GenCos and DisCos → improvement of quantity and quality of the power supply → yielding customers' willingness to pay for reliable, affordable energy.

#### 4.2.2 Recommendations to JICA

JICA has aided developing countries not only in the construction of lifeline facilities, but also in establishing systems where beneficiaries pay for the services. It is very likely that JICA's experience is primarily in the water resources sector, especially water supply projects as well as the electricity sector. There are many cases where the sustainability of lifeline facilities assisted by JICA depends on the 'willingness to pay' by the beneficiaries<sup>35</sup>. Based on such experiences, JICA should advise the FMWPH that the success of the Project and the Nigerian electricity market depends on the electricity bills being paid by the end users, and provide advice on actions the FMPWH should take to raise their willingness to pay.

#### 4.3 Lessons Learned

##### Response to delays by external factors

The Project was substantially delayed. The reasons include external factors such as the deterioration of security (the main reason), and delay in the dispatch of supervisors from the water turbine manufacturer. Even if the Japanese side had taken the most extreme security countermeasures, such measures would not have been effective in the circumstance where a national state of emergency was declared, and delays by external factors such as the delayed dispatch of supervisors could not have been avoided. In such a situation, the persons concerned consistently carried out "what you must do" and "what you can do" as the second-best measure. As a result, smooth progress after the start of the site work was ensured without human or physical losses.

In the case of the Project, there were several things pertaining to "what you must do" and "what you can do" during the period when no site works could be started: continuous acquisition of information on site security and sharing it among the persons concerned through site meetings, and confirmation of shipping, unloading and storage of the procured machinery and equipment. Hereafter, it is expected that in the case where site work becomes temporarily impossible projects requiring equipment provision, consistent implementation of "what you must do" and "what you can do" will lead to smoother progress after starting or restarting site works once the situation improves.

End

---

<sup>35</sup> For example, some JICA projects that aimed to improve water supply in rural areas are listed in the Ex-post Evaluation Report of "The Water Sector Capacity Development Project in Southern Nations, Nationalities and People's Region" in Ethiopia.